

Item	Qty.	Description
4A,4B	1,1	130.495" Z245 curved Extrusion
5A,5B	1,1	14.783"w S44 Horizontal Extrusion

- Steps:**
- 1) Assemble curved extrusions [4A-4B] together. See **Z245 Spline Connection** detail.
 - 2) Attach angled ends of horizontals [5A,5B] to assembly [4A/4B] as shown. See **S44 to Z245 Connection** detail.
 - 3) Connect horizontal [5A] to Wall horizontal [9B]; attach horizontal [5B] to Wall horizontal [13B] as shown.
 - 4) Lock horizontals [3] to curved assembly [4A/4B], securing infills.

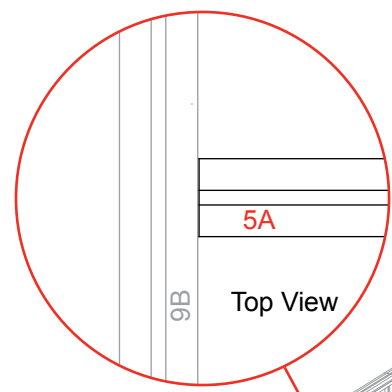

Section Being Assembled is Highlighted in BLACK

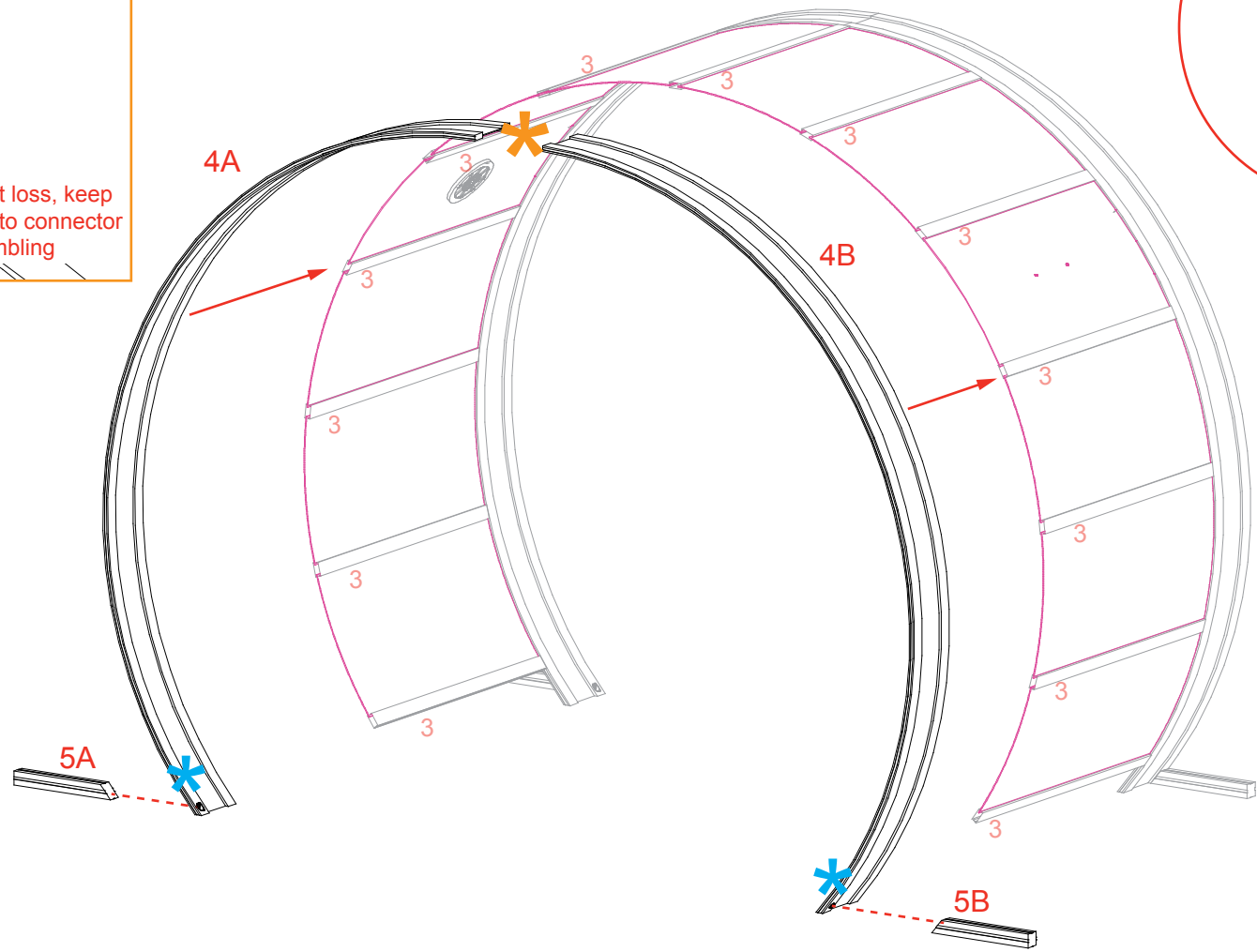
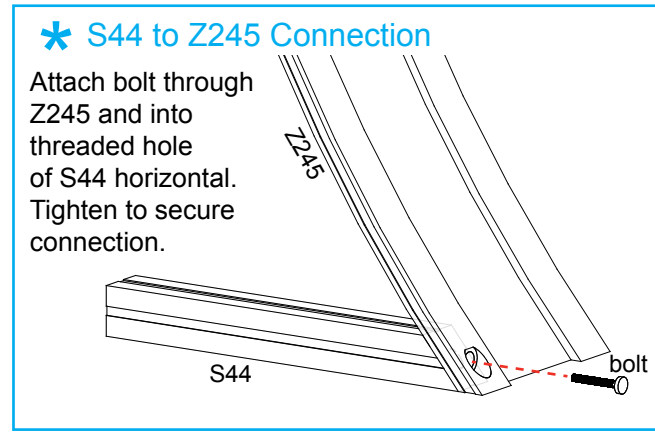
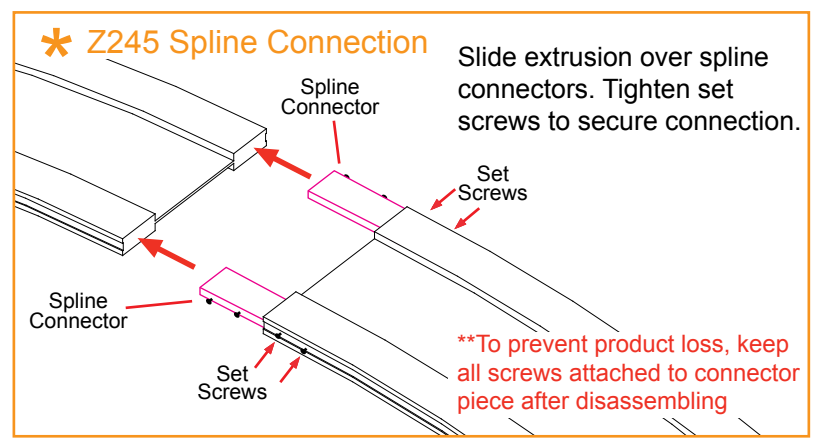
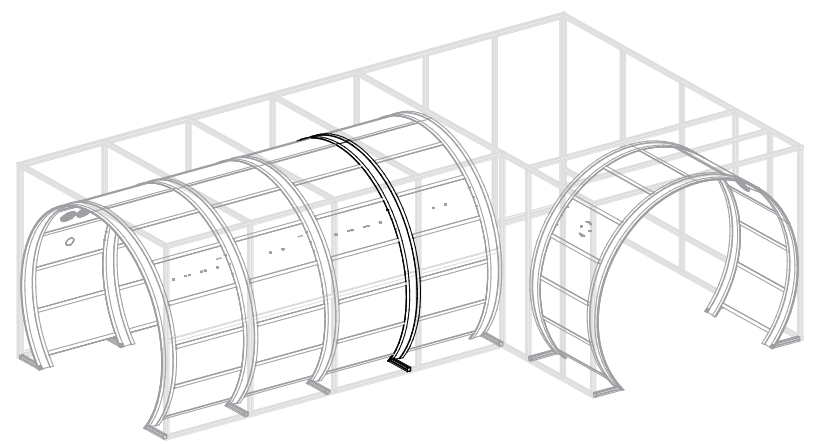