

*** Custom Cam Lock Connection**

Attach cam lock to adjoining extrusion; tighten set screw to secure connection.

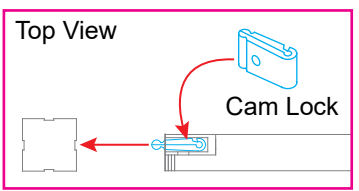

*** Bolt to T-Nut Connection**

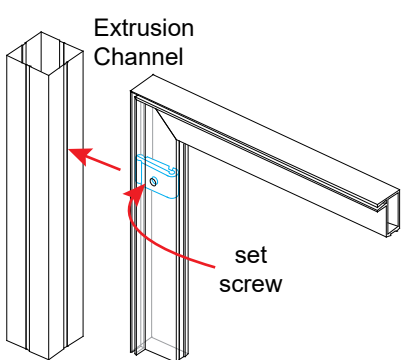
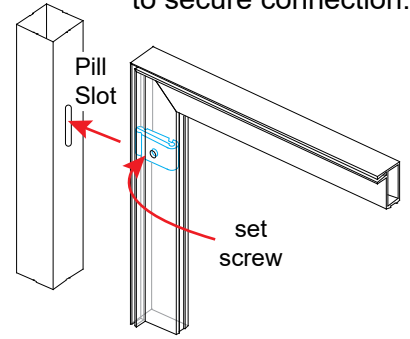
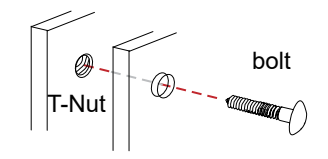

Steps:

- 1) Attach header lightbox verticals [7,8] to front of closet panel [A] using Bolt to T-Nut Connection.
- 2) Connect header frame assembly [1/2/18/19] to side of lightbox vertical [5], using standoff barrels & V4 connectors. See Standoff Barrel & V4 Attachment detail.
- 3) Lock extrusion [9] to underside of header frame horizontal [18]; attach extrusion [9] to lightbox vertical [5] using standoff barrel, standoff cap & V4 connector as shown.
- 4) Connect header frame [5/6/20/21] to header lightbox vertical [1] using custom cam lock. See Custom Cam Lock Connection detail.
- 5) Attach header vertical [2] to pill slot on header vertical [5] using custom cam lock. See Custom Cam Lock Connection detail.

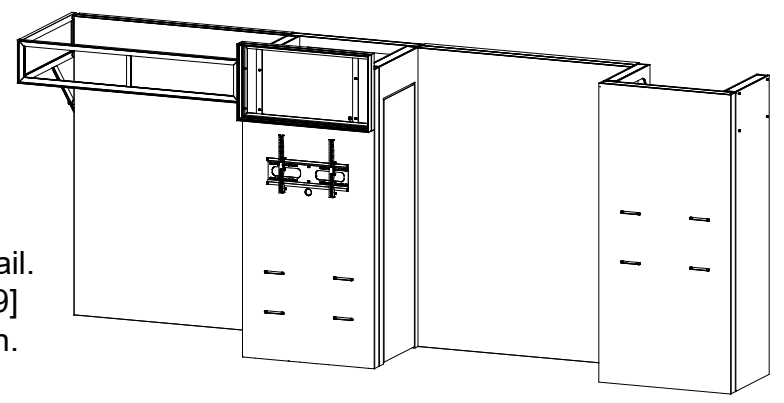

When assembled

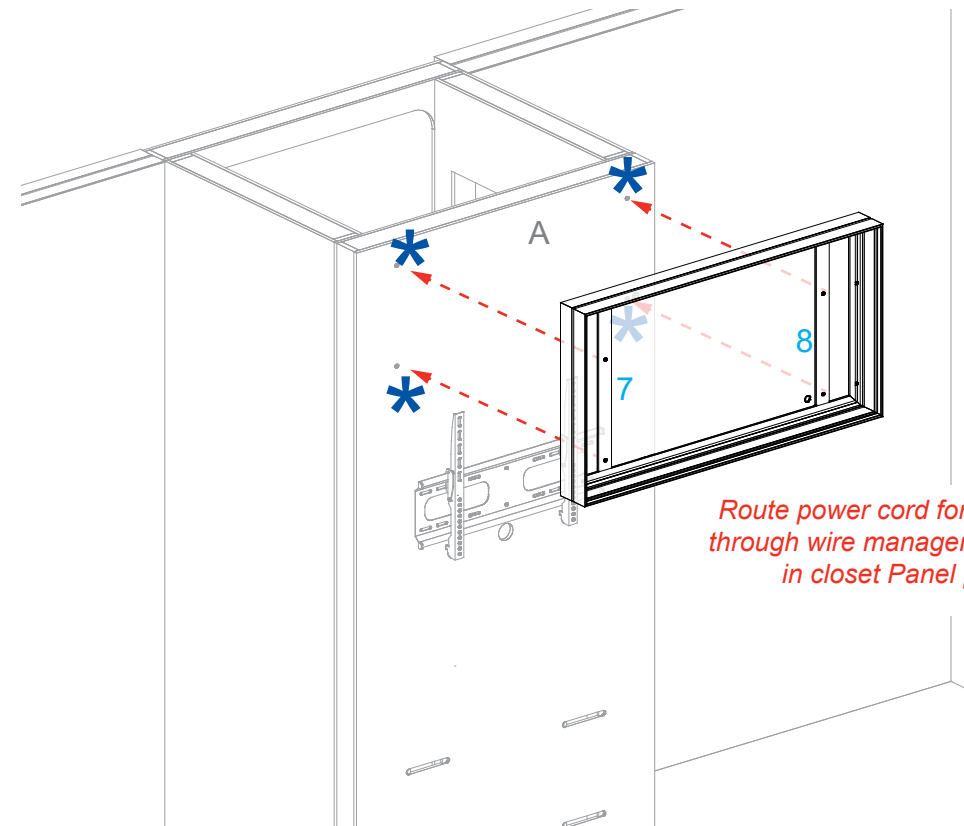

| Item | Qty. | Description |
|------|------|--------------------------|
| 9 | 1 | 24" angled Z45 Extrusion |

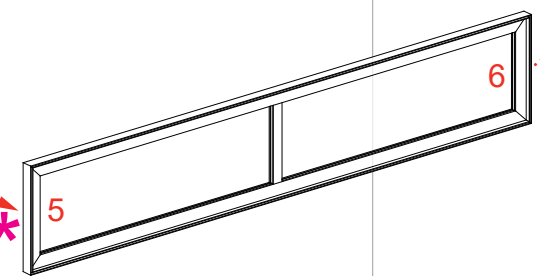
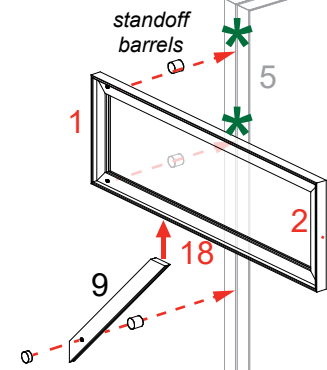

*** Standoff Barrel & V4 Attachment**

Slide V4 Connector into groove of vertical extrusion. Tighten set screws to secure in place. Attach Standoff to V4.

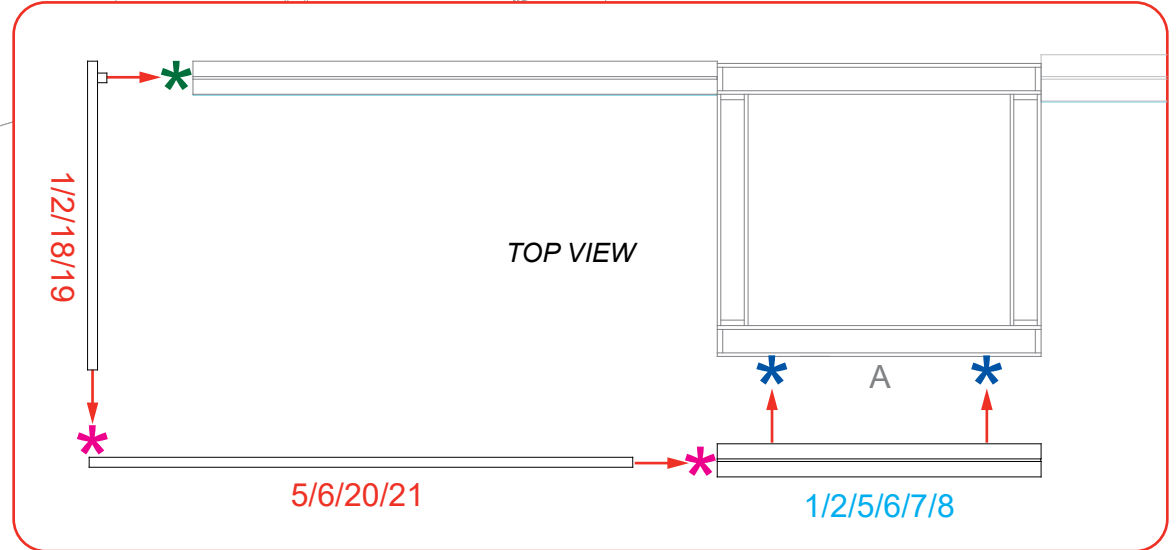
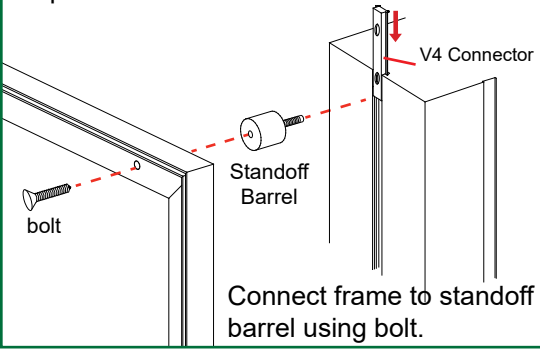

Gusset Attachment

